

MODEL: CC001

You will receive **2** cartons. Before assembly, confirm that all components are present.

18x9FT

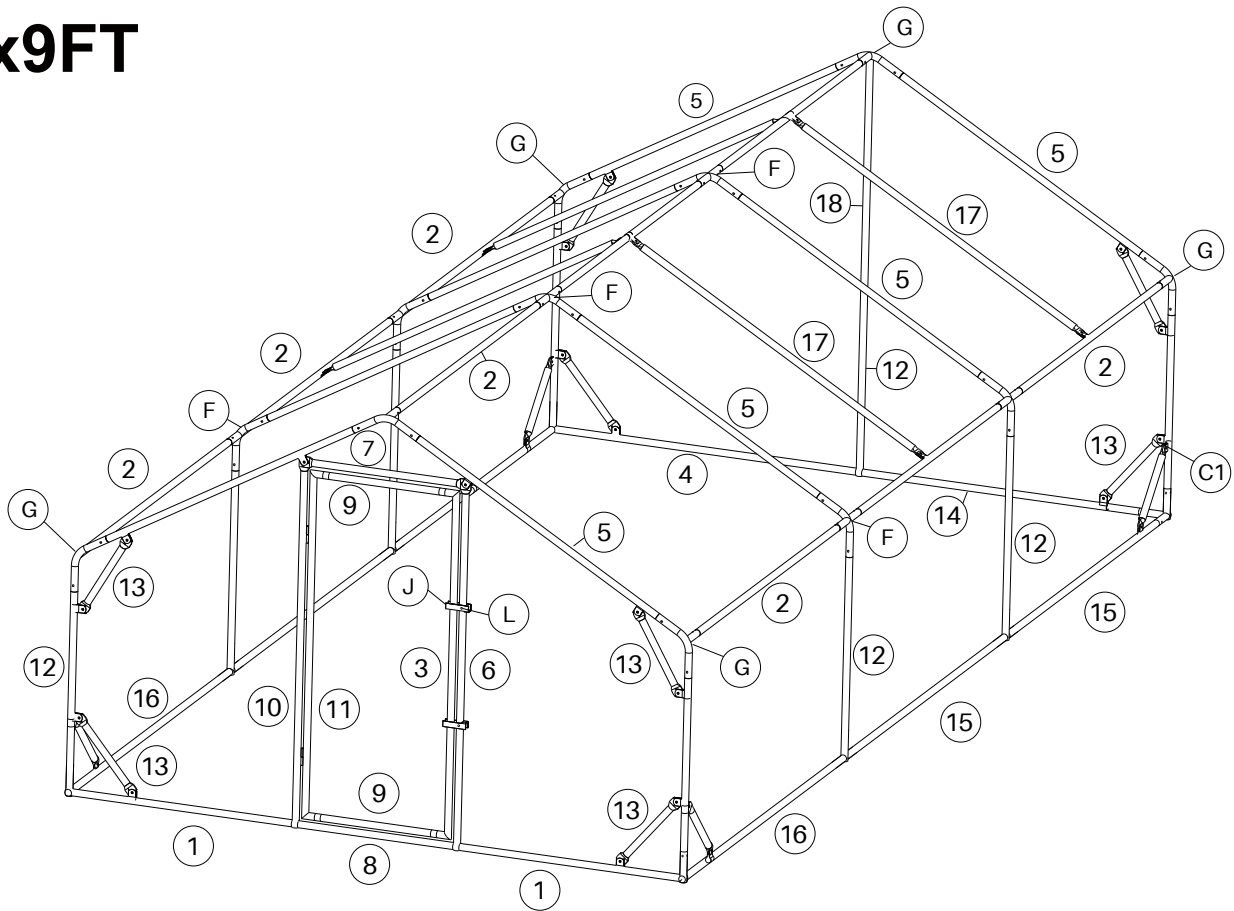

For more details about the assembly, please refer to the video on the product listing page.





Please contact our support team whenever you need help.





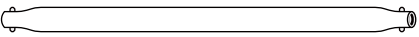
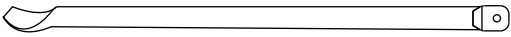
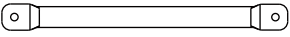
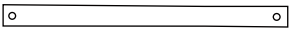
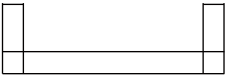
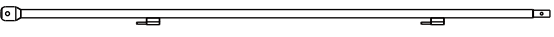
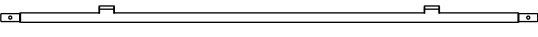
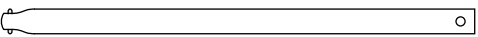
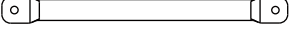
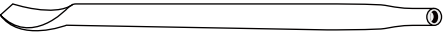

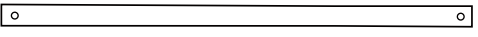
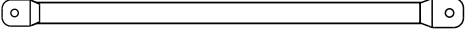

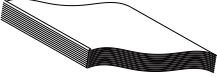
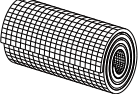

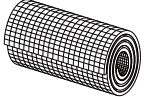

Email: maxlead.us@gmail.com

Tel: 302-261-5366

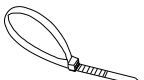
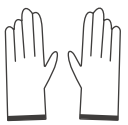

Part Number	Diagram	Description	Quantity (PCS)
#1		Long Front Pole	2
#2		Side Pole 1	9
#3		Short Inner Door Pole with 2 holes	1
#4		Back Pole 1	1

Part Number	Diagram	Description	Quantity (PCS)
#5		Roof Pole	8
#6		Long Outer Door Pole (with 2 Holes)	1
#7		Door Top Cross Pole	1
#8		Short Front Pole	1
#9		Inner Door Bend Pole	2
#10		Long Outer Door Pole	1
#11		Short Inner Door Pole	1
#12		Side Standing Pole	9
#13		Bottom Bracing Pole	12
#14		Back Pole 2	1
#15		Side Pole 2	4
#16		Side Pole 3	2
#17		Top Bracing Pole	4
#18		Back Standing Pole	1
#P		Roof Cover	2
#Q1		Hardware Cloth	1

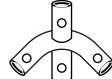
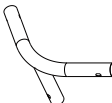
Part Number	Diagram	Description	Quantity (PCS)
#Q2		Chicken Wire	1
#F3		M6*35 Screws & Nuts	2
#F4		M6*60 Screws & Nuts	9
#F5		M6*20 Screws & Nuts	35
#X		Screw Cap	46
#L		M8*50 Screws & Nuts	2
#J		Door Switch	2
#C1		Pipe Clamp	35
#O		Bungee Ball	24
#T1		Wrench M6	1
#T2		Wrench M8	1
#N		Zip Tie	750
#S		Gloves	1
#W		Ground Stake	24
#M		Riding Buckle	12
#F		4-Way Connector	6
#G		3-Way Connector	6

Assemble

For visual guidance, please refer to the online installation video or contact us.

Step 1. Pre-install one screw F4 at the connection point of Poles 4 and 14 , F3 at Poles 1 and 8 without attaching the nut.

Part Number	#1	#8	#15	#16	#12	#4	#14	#F3	#F4
Quantity (PCS)	2	1	4	2	8	1	1	2	9

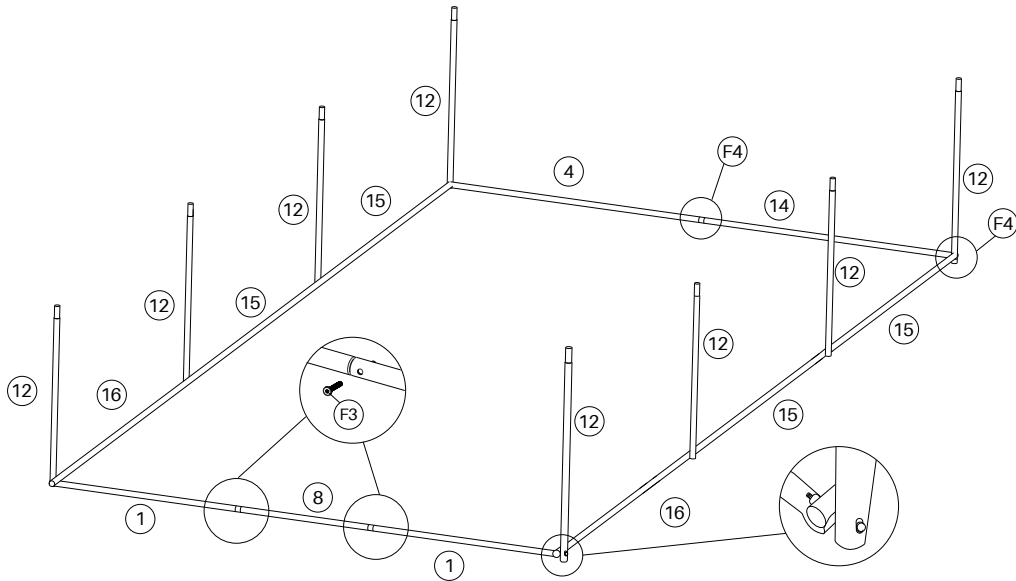

Step 2.

Part Number	#G	#F	#5	#2
Quantity (PCS)	3	3	4	2

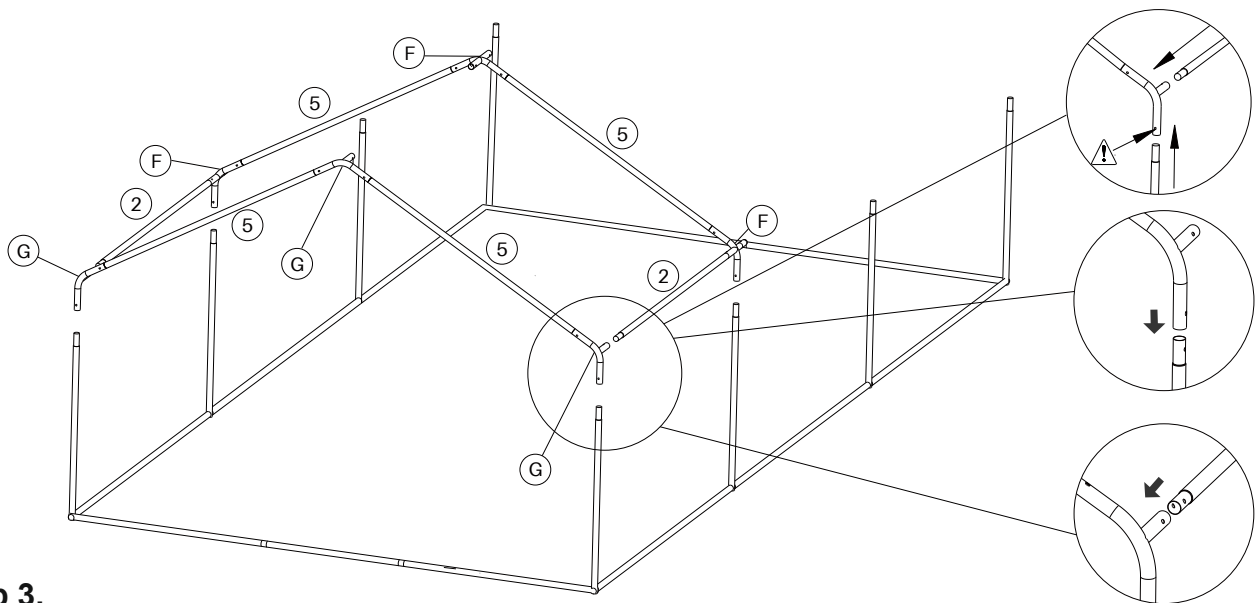

Step 3.

Part Number	#5	#2	#G	#F
Quantity (PCS)	4	7	3	3

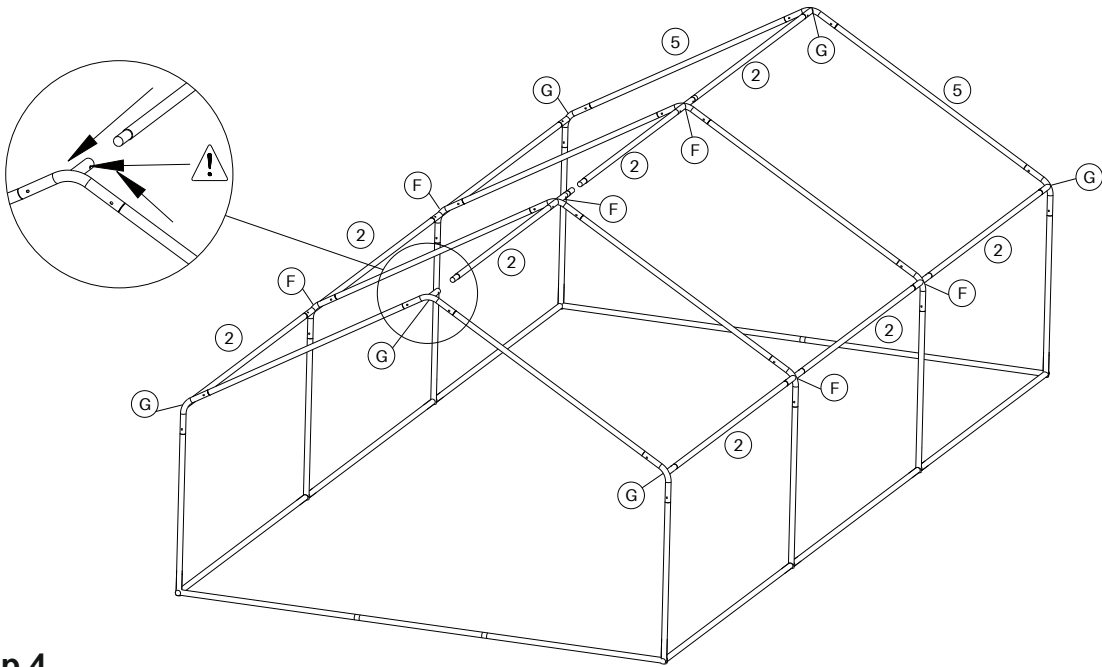

Step 4.

Part Number	#3	#6	#7	#9	#10	#11	#J	#F5	#C1	#L
Quantity (PCS)	1	1	1	2	1	1	2	2	2	2

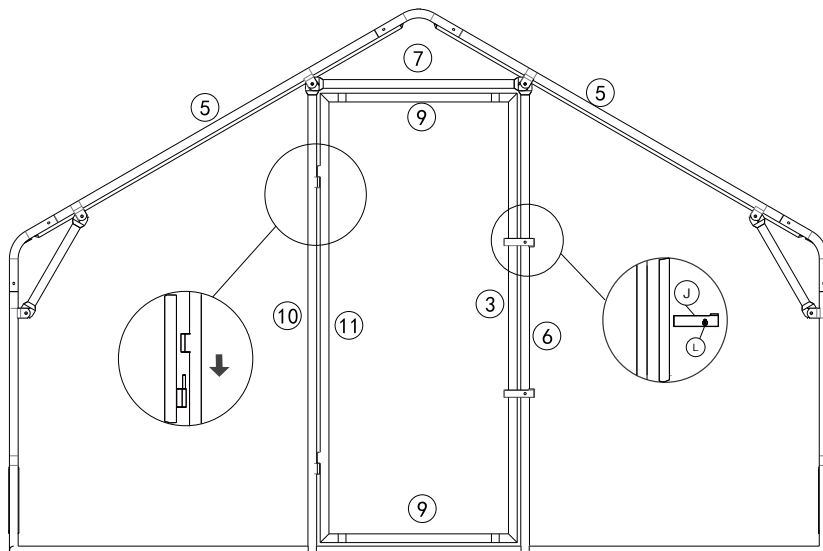
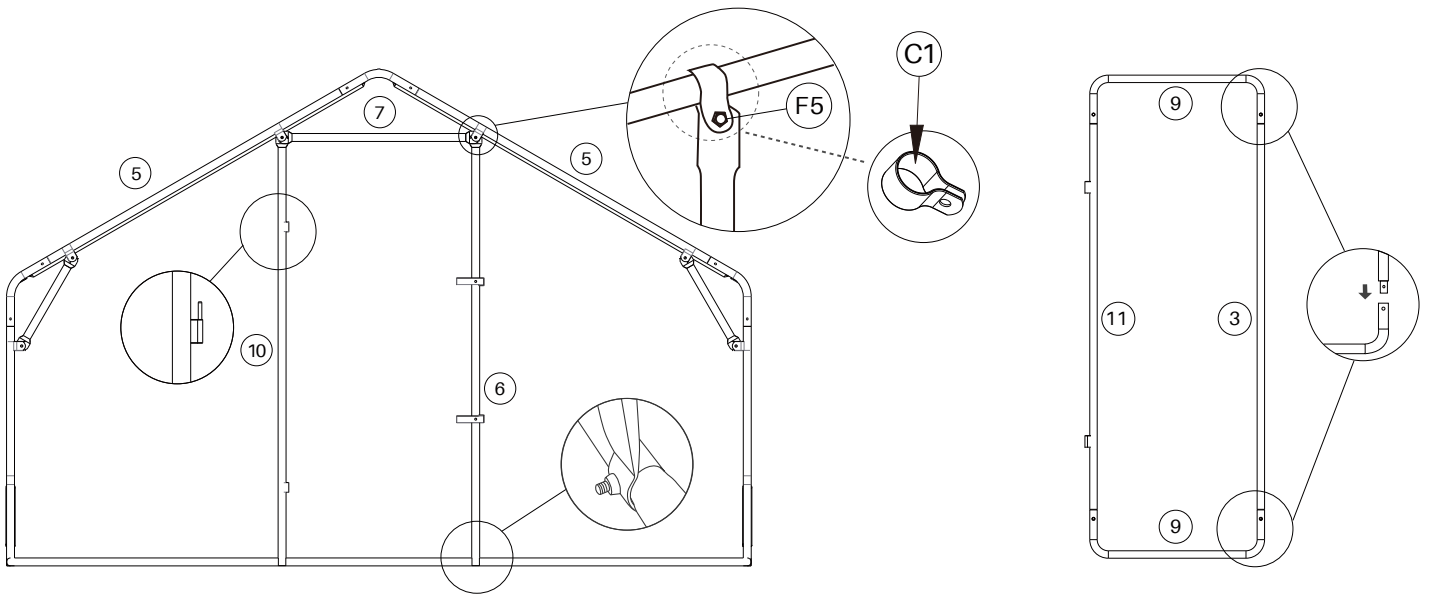

Step 5.

Part Number	#13	#C1	#F5	#12	#18
Quantity (PCS)	12	25	25	1	1

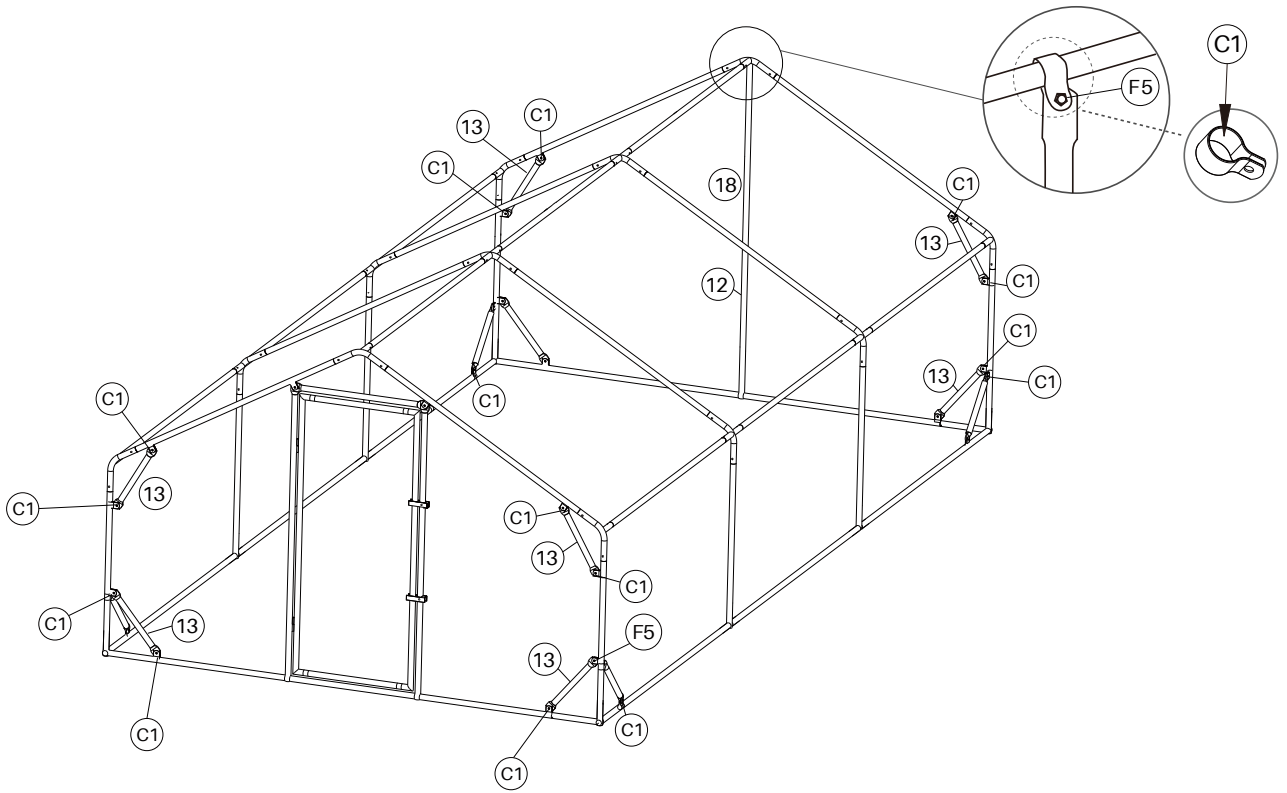

Step 6. Install Pole #17 under the area where the top cover will be placed, as it is designed to support the cover from beneath.

Part Number	#17	#C1	#F5	#W	#M
Quantity (PCS)	4	8	8	24	12

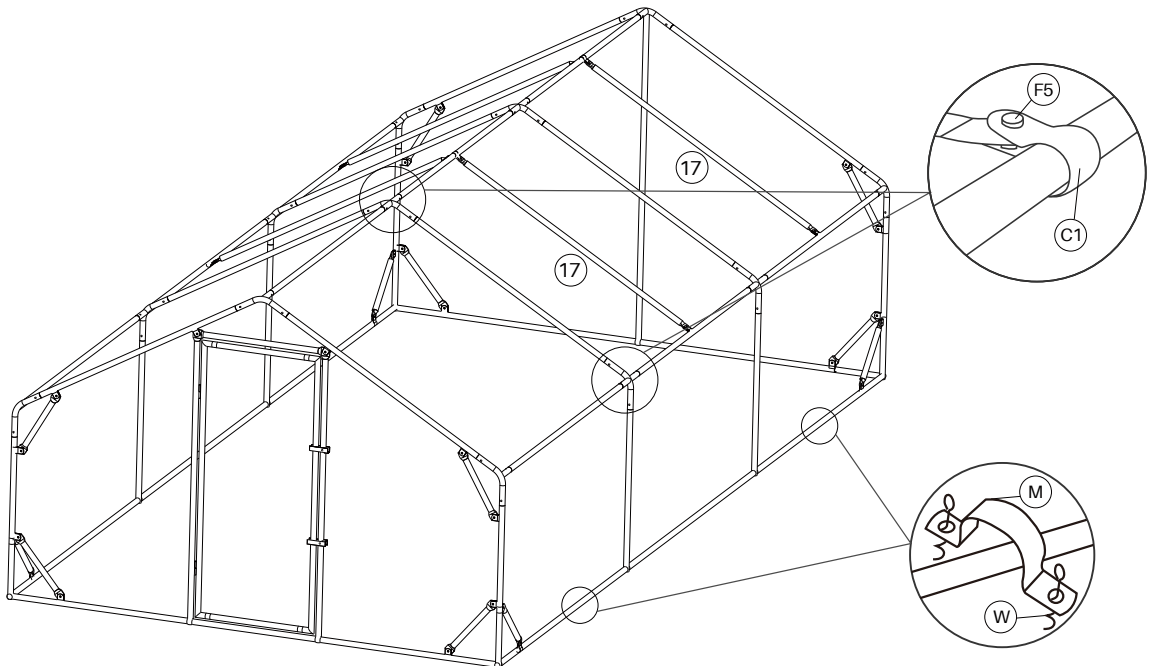

- Step 7.**
1. Precisely measure each side length as shown in the diagram.
 2. Pre-cut the corners according to the illustration. The cut length determines the ground extension of the mesh—recommended 1–1.3 ft to deter digging by predators; do not exceed 1.6 ft. Use wire cutters suitable for metal mesh.
 3. Attach the mesh to the frame in order using the provided zip ties.
 4. Weigh down extended edges with bricks or stones.
 5. Secure the bottom wire to poles firmly with zip ties.

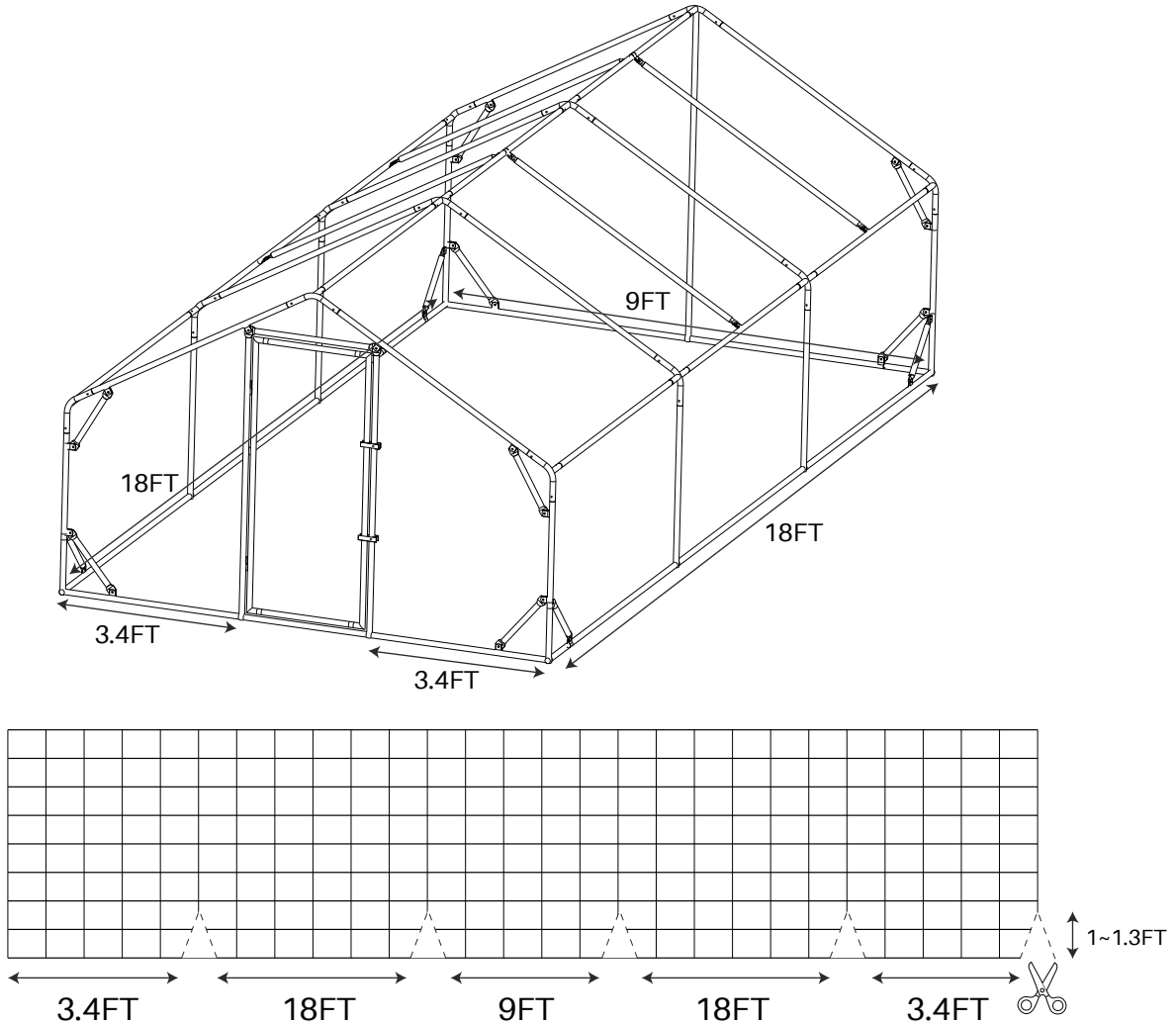

Step 8.

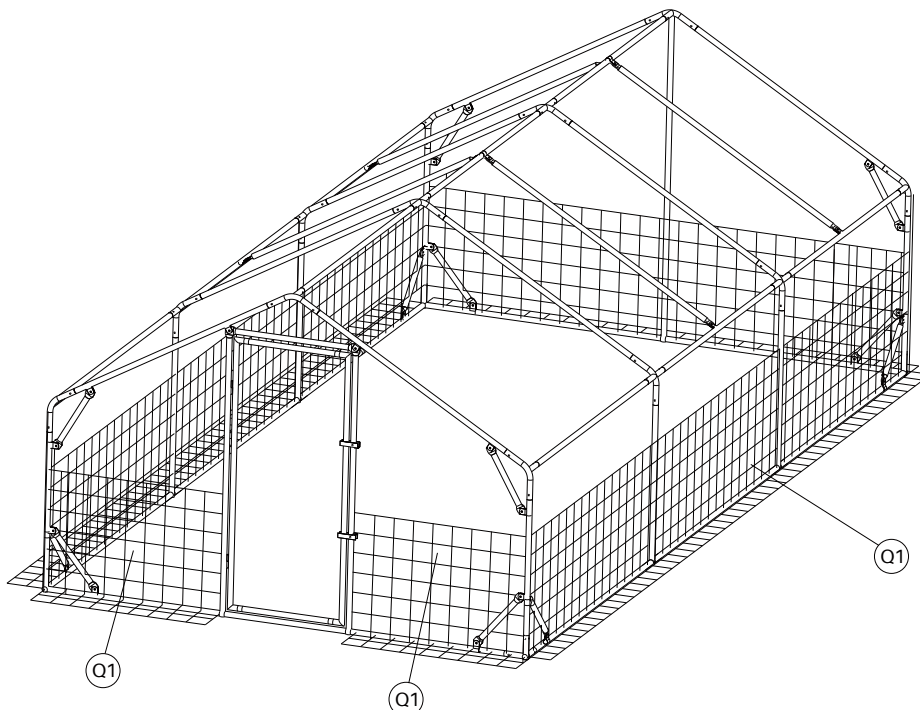

- Step 9.** 1. Overlap mesh sections by approximately 8 inches.
2. Space zip ties 6-8 inches apart along the base.
3. Space zip ties 8 inches or more apart along the top.

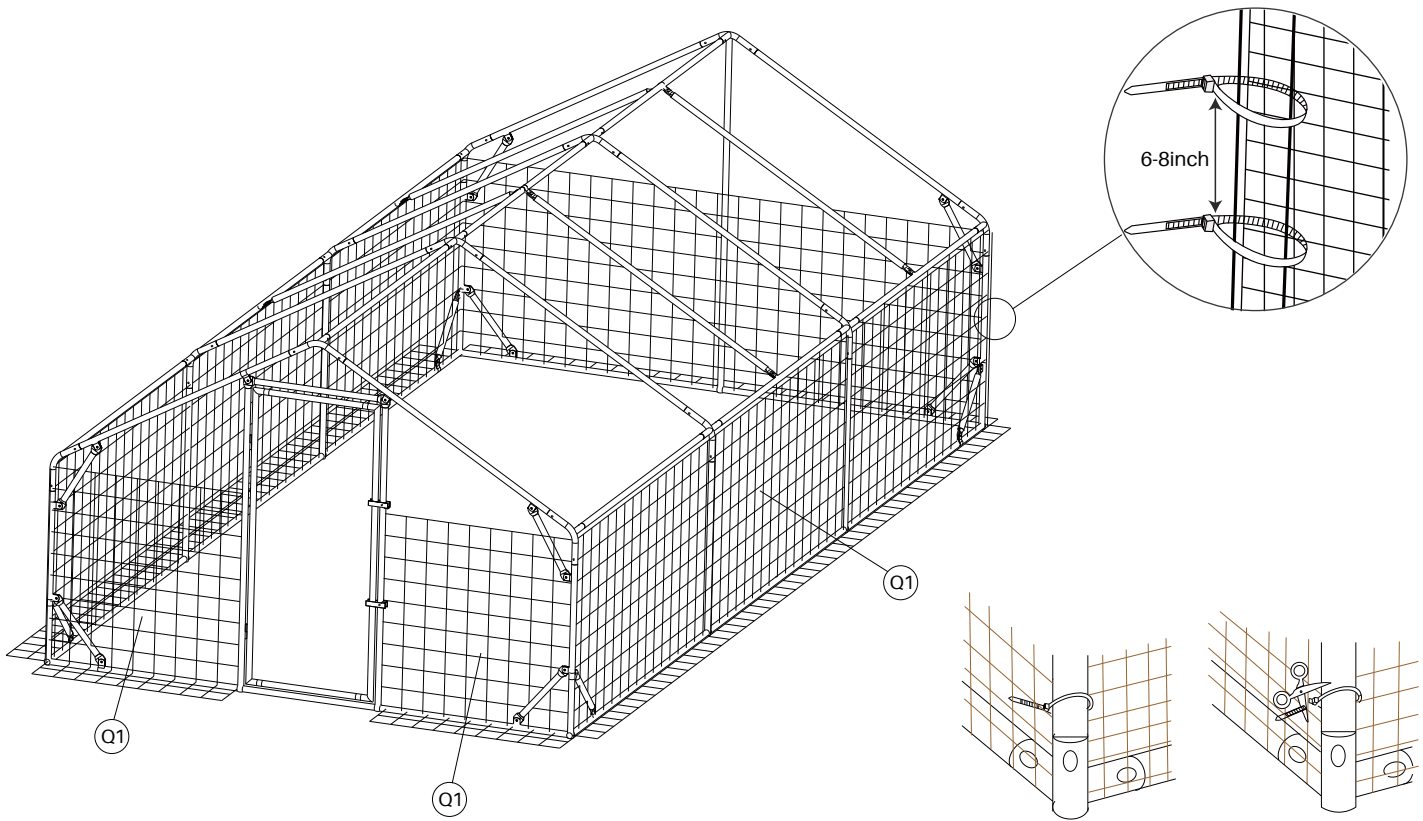

- Step 10.** Secure one side of the mesh with zip ties. Pull the mesh taut, then secure the opposite side. Ensure the mesh is tightly stretched and free of sagging.

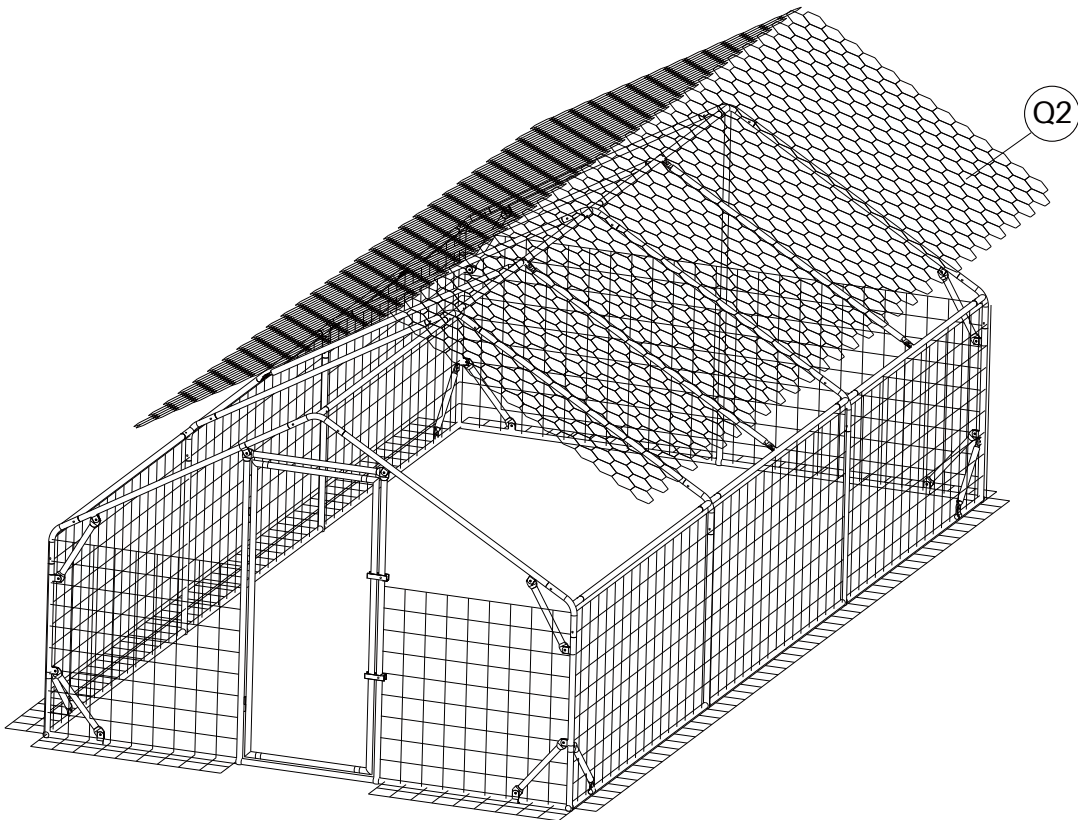

Step 11.

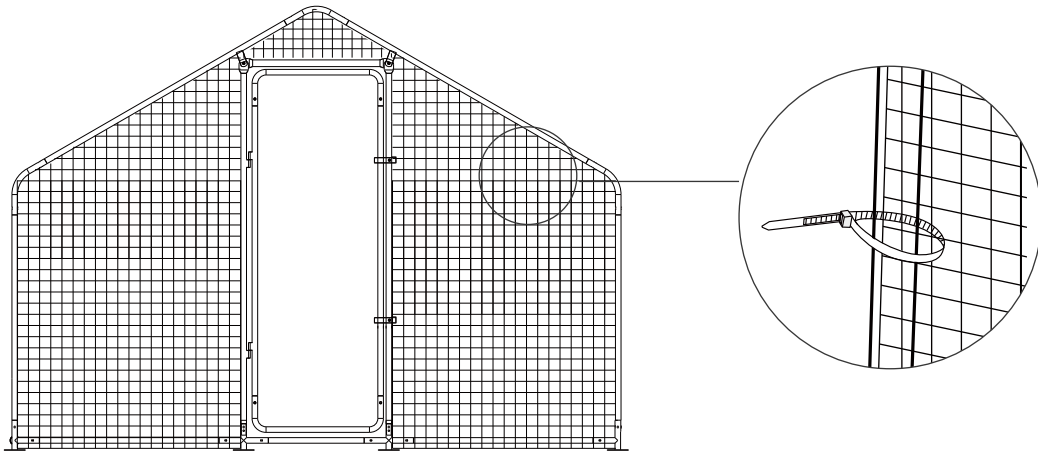
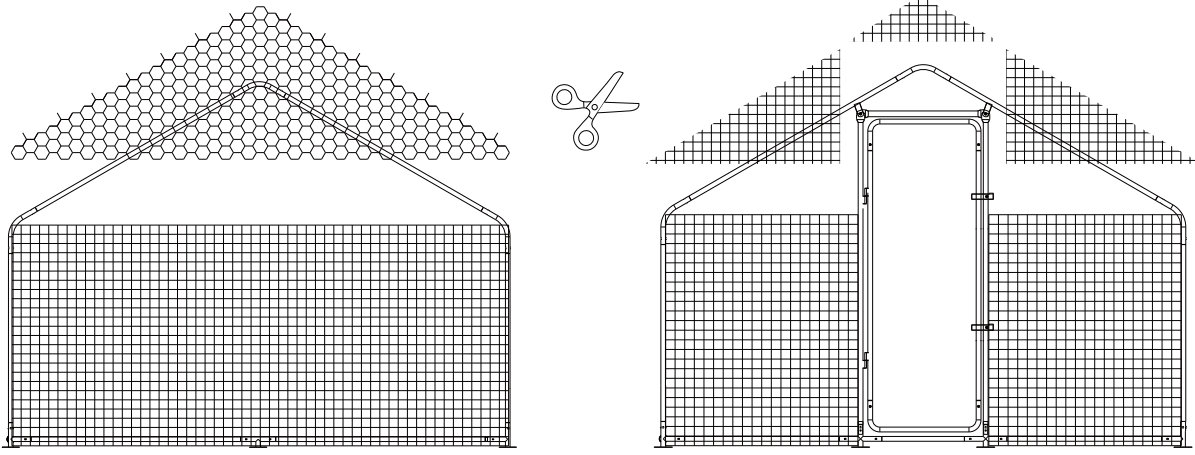

Step 12.

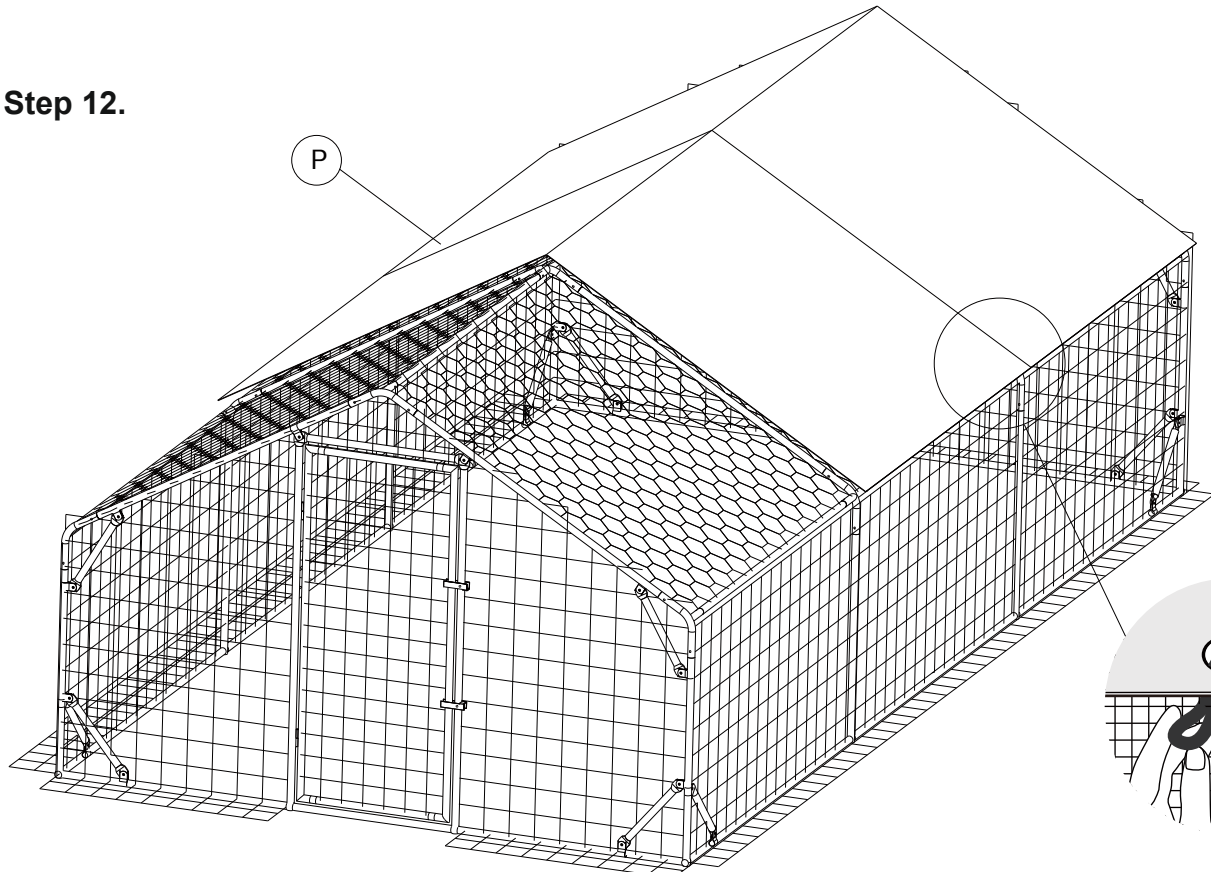

Warning

Restructuring the product without written permission from Quiccent in advance would VOID the warranty.

Damages due to improper use in severe weather conditions, including but not limited to high winds, heavy rain, sleet, snow, etc., will NOT be covered by the warranty.

Warranty

The limited warranty covering the materials and the craftsmanship under normal use and service conditions takes effect from the purchase date (on thinvoice).

Please note that the order purchase proof (order number or shipping information on the shipping carton) is the only valid evidence to claim for warranty

365-day warranty for the Pole and Connector.

180-day warranty for the Cover and Net.

For more details about the assembly, please scan the QR code on the Transparency Program card to watch the installation video. Please check the after-sales contact information on the card.



Email: maxlead.us@gmail.com

Tel: 302-261-5366

QT2509245139